

67CF Series Filter Regulators

- ☆ Compact and Light Weight
- ☆ Designed for Digital Instrumentation
- ☆ No Air Loss
- ☆ Easy Maintenance



A 67CF Series regulator used as a pilot supply regulator for the Type 299 pressure regulator



A 67CF Series filter regulator shown with optional pressure gauge



A 67CF Series regulator used as a supply regulator for digital instrumentation

- ☆ High Performance
- ☆ Integral Filter
- ☆ Internal Relief Valve
- ☆ Rugged Construction



Introduction

The 67CF Series regulators are typically used to provide constantly controlled, reduced pressures to pneumatic and electropneumatic controllers and other instruments. These direct-operated regulators are suitable for most air or gas applications. Other applications include providing reduced pressures to air chucks, air jets, and spray guns.

Features

- **Compact**—The 67CF Series regulators are engineered for outstanding performance in a compact, light-weight package.
- **Internal Relief**—The Type 67CFR has an internal relief valve with a soft seat for reliable shutoff with no discernible leakage.
- **Panel Mounting**—Panel mount construction includes spring case with 1/4-inch NPT vent, handwheel adjusting screw, and mounting nut.
- **Instrument Supply Regulator**—Provides a clean air supply to a variety of pneumatic and electro-pneumatic instrumentation.
- **Digital Instrument Supply Regulator**—Designed for the accuracy, repeatability, and hysteresis demands of digital instrumentation.
- **Pilot Supply Regulator**—Improves the accuracy of two-path control regulators by reducing inlet sensitivity caused by fluctuating inlet pressures.
- **Pressure Loading Regulator**—Provides high accuracy and improved performance in dirty steam service by eliminating the need for a pilot regulator (see figure 2).
- **Sour Gas Service Capability**—NACE (MR0175) compliant construction available.
- **Integral Filter**—An integral filter ensures clean downstream air supply.
- **Ease of Maintenance**—No special tools are required to perform maintenance, and all maintenance can be performed with the regulator in the line. Filter elements are easily replaced. The one-piece valve plug cartridge allows easy inspection and replacement.

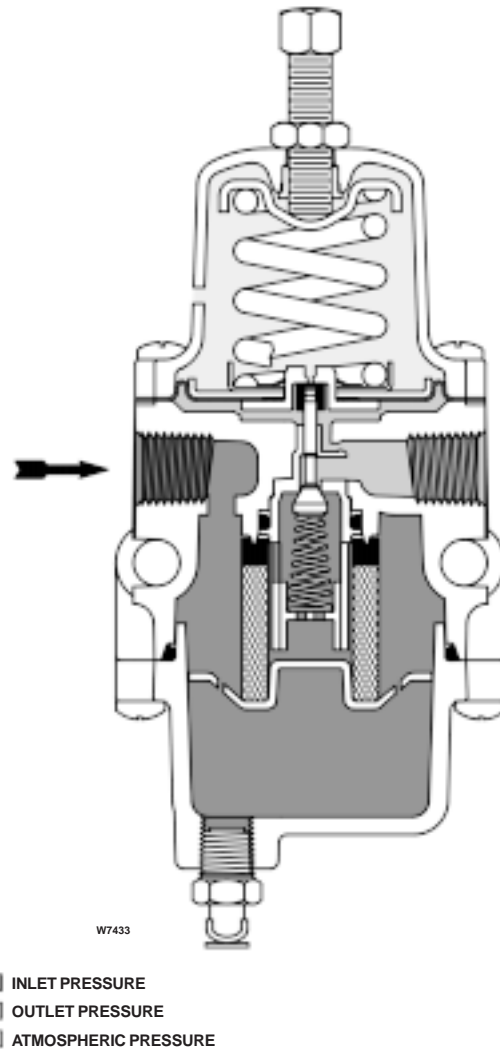

Figure 2. 67CF Series Regulator Operational Schematic

- **Rugged Construction**—The 67CF Series regulators are engineered for longer service life with minimal maintenance requirements.
- **Second Outlet**—Body side outlet for pressure gauge or other uses.
- **Powder Paint Coating**—Fisher products are powder paint coated, offering impact, abrasion, and corrosion resistance.
- **Corrosion Resistant Fasteners**—Adjusting screw and screws are double zinc-chromated for enhanced corrosion resistance.
- **Full Usable Capacity**—Fisher regulators are laboratory tested. 100 percent of the published capacities can be used with confidence.

Specifications

Body Size, Inlet and Outlets Connection Style

1/4-inch NPT screwed

Maximum Inlet Pressure (Body Rating)⁽¹⁾

250 psig (17,2 bar)

Outlet Pressure Ranges

OUTLET PRESSURE RANGES, PSIG (bar)	CONTROL SPRING DATA		
	Part Number	Color	Wire Diameter, Inch (mm)
0 to 20 (0 to 1,4)	T14130T0012	green stripe	0.135 (3,43)
0 to 35 (0 to 2,4)	T14059T0012	silver	0.156 (3,96)
0 to 60 (0 to 4,1)	T14058T0012	blue stripe	0.170 (4,32)
0 to 125 (0 to 8,6)	T14060T0012	red stripe	0.207 (5,26)

Maximum Emergency Outlet Pressure⁽¹⁾

50 psi (3,4 bar) over outlet pressure setting

Capacities

See table 1

Wide-Open Flow Coefficients

Main Valve: C_g : 11.7; C_v : 0.36; C_r : 32.2

Internal Relief Valve: C_g : 1.45; C_v : 0.045; C_r : 32.8

Pressure Registration

Internal

Accuracy

Inlet Sensitivity: Less than 0.2 psig (0,014 bar) change in outlet pressure for every 25 psig (1,72 bar) change in inlet pressure

Repeatability: 0.1 psig (0,0069 bar)⁽²⁾

Air Consumption: testing repeatedly shows no discernible leakage

Type 67CFR Internal Relief Performance

Low capacity for minor seat leakage only; other overpressure protection must be provided if inlet pressure can exceed the maximum pressure rating of downstream equipment or exceeds maximum outlet pressure rating of the Type 67CFR

Filter Capabilities

Free Area: 12 times pipe area

Micron Rating:

Cellulose Element: 40 microns

Glass Fiber Element: 10 microns

Stainless Steel Element: 40 microns

Regulator Temperature Capabilities

With Nitrile (NBR):

-40° to 180°F (-40° to 82°C)

With Fluoroelastomer (FKM):

0° to 300°F (-18° to 149°C)

With Silicone (VMQ)⁽³⁾:

-60° to 180°F (-51° to 82°C)

Drain Valve and Spring Case Vent Location

Aligned with inlet standard, other positions optional

Approximate Unit Weight

1 pound (0,5 kg)

Construction Materials

Body, Spring Case and Dripwell: Aluminum (ASTM B85/Alloy 380)

Pusher Post: Polyester resin

Upper Spring Seat: Zinc-plated steel

Diaphragm Plate: Zinc-plated steel

Adjusting Screw: Zinc-plated steel

Filter Retainer: Zinc-plated steel

Valve Plug: Brass stem with nitrile (NBR) plug (standard); aluminum stem with nitrile (NBR) or fluoroelastomer (FKM) plug; or stainless steel stem with nitrile (NBR) or fluoroelastomer (FKM) plug (optional)

Soft Seat: Nitrile (NBR) (standard), or fluoroelastomer (FKM) (optional)

Diaphragm and O-Rings: Nitrile (NBR) (standard), fluoroelastomer (FKM), or silicone (VMQ) (optional)

Control Spring: Plated steel (standard) or Inconel (for 67CFR NACE)

Valve Spring: Stainless steel (standard) or Inconel (NACE)

Drain Valve: Brass (standard), aluminum, or stainless steel (optional)

Filter Element: Cellulose (standard), glass fiber, or stainless steel (optional)

Options

- Handwheel adjusting screw
- NACE construction
- Ammonia service construction
- Panel mount (includes spring case with 1/4-inch vent, handwheel, and panel mounting nut)
- Closing cap (available on spring case with 1/4-inch NPT vent)
- Aluminum or stainless steel drain valve
- Fluoroelastomer (FKM) elastomers for high temperatures and/or corrosive chemicals
- Silicone (VMQ) elastomers for cold temperatures
- Triple scale outlet pressure gauge (brass or stainless steel)
- Stainless steel stem on the valve plug
- Fixed bleed restriction mounted in the side outlet
- Tire valve in second outlet
- Pipe plug in second outlet

1. The pressure/temperature limits in this bulletin and any applicable standard or code limitation should not be exceeded.
 2. Repeatability is the measure of the regulator's ability to return to setpoint consistently when traveling from steady state to transient to steady state.
 3. Silicone is not compatible with hydrocarbon gas.

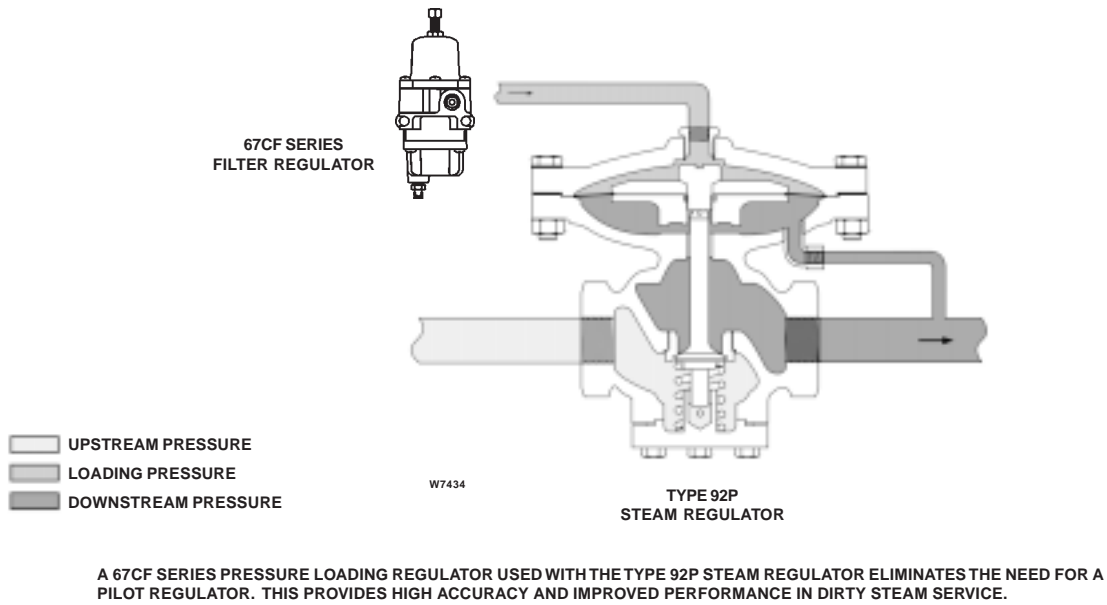

Figure 3. 67CF Series Regulator Used to Pressure Load a 92P Steam Regulator

Capacity Information

Table 1 shows the air regulating capacities of the 67CF Series regulators at selected inlet pressures and outlet pressure settings. Flows are shown in scfh (at 60°F and 14.7 psia) and in m³/h(n) (at 0°C and 1,01325 bar) of air.

Note

The 67CF Series regulators may be sized for 100% flow using capacities as shown in table 1. It is not necessary to reduce published capacities.

To determine the equivalent capacities for other gases, multiply the table capacity by the following appropriate conversion factor: 1.29 for 0.6 specific gravity natural gas, 0.810 for propane, 0.707 for butane, or 1.018 for nitrogen. For gases of other specific gravities, divide the table capacities by the square root of the appropriate specific gravity.

To find wide-open flow capacities for relief sizing at any inlet pressure, perform one of the following procedures. Then, if necessary, convert using the factors provided above.

For critical pressure drops (absolute outlet pressure equal to or less than one-half of absolute inlet pressure), use the following formula:

$$Q = (P_1)(C_g)$$

where,

$$Q = \text{gas flow rate, scfh}$$

$$P_1 = \text{absolute inlet pressure, psia}$$

$$(P_1 \text{ gauge} + 14.7)$$

For pressure drops lower than critical (absolute outlet pressure greater than one-half of absolute inlet pressure), use the following formula:

$$Q = \sqrt{\frac{520}{GT}} C_g P_1 \text{SIN} \left(\frac{3417}{C_1} \sqrt{\frac{\Delta P}{P_1}} \right) \text{DEG}$$

where,

$$Q = \text{gas flow rate, scfh}$$

$$G = \text{specific gravity of the gas}$$

$$T = \text{absolute temperature of gas at inlet, } ^\circ\text{Rankine}$$

$$C_g = \text{gas sizing coefficient}$$

$$P_1 = \text{absolute inlet pressure, psia}$$

$$C_1 = \text{flow coefficient } (C_g \div C_v)$$

$$\Delta P = \text{pressure drop across the regulator, psi}$$

Then, if capacity is desired in normal cubic meters per hour (at 0°C and 1,01325 bar), multiply scfh by 0.0268.

Table 1. Capacities

OUTLET PRESSURE RANGE, SPRING PART NUMBER AND COLOR, PSIG (bar)	OUTLET PRESSURE, PSIG (bar)	INLET PRESSURE, PSIG (bar)	CAPACITIES IN SCFH (m ³ /h(n)) OF AIR	
			10% Droop	20% Droop
0 to 35 (0 to 2,4) T14059T0012 Silver	15 (1,0)	50 (3,4)	250 (6,7)	430 (11,5)
		75 (5,2)	300 (8,0)	690 (18,5)
		100 (6,9)	330 (8,8)	1150 (30,8)
		150 (10,3)	400 (10,7)	1600 (42,9)
		250 (17,2)	450 (12,1)	1800 (48,2)
	20 (1,4)	50 (3,4)	350 (9,4)	500 (13,4)
		75 (5,2)	530 (14,2)	820 (22,0)
		100 (6,9)	750 (20,1)	1300 (34,8)
		150 (10,3)	1850 (49,6)	1850 (49,6)
35 (2,4)	250 (17,2)	2800 (75,0)	3000 (80,4)	
	50 (3,4)	400 (10,7)	620 (16,6)	
	75 (5,2)	600 (16,1)	980 (26,3)	
	100 (6,9)	840 (22,5)	1300 (34,8)	
	150 (10,3)	1850 (49,6)	1850 (49,6)	
0 to 60 (0 to 4,1) T14058T0012 Blue stripe	35 (2,4)	250 (17,2)	3000 (80,4)	3000 (80,4)
		50 (3,4)	370 (9,9)	560 (15,0)
		75 (5,2)	540 (14,5)	940 (25,2)
		100 (6,9)	760 (20,4)	1300 (34,8)
		150 (10,3)	1360 (36,4)	1850 (49,6)
	60 (4,1)	250 (17,2)	2900 (77,7)	3000 (80,4)
		75 (5,2)	570 (15,3)	830 (22,2)
		100 (6,9)	830 (22,2)	1220 (32,7)
		150 (10,3)	1450 (38,9)	1850 (49,6)
0 to 125 (0 to 8,6) T14060T0012 Red stripe	80 (5,5)	250 (17,2)	1400 (37,5)	2500 (67)
		150 (10,3)	880 (23,6)	1320 (35,4)
		100 (6,9)	600 (16,1)	870 (23,3)
	125 (8,6)	250 (17,2)	1700 (45,6)	2580 (69,1)
		150 (10,3)	960 (25,7)	1400 (37,5)
		100 (6,9)	600 (16,1)	870 (23,3)

Overpressure Protection

The 67CF Series regulators have maximum outlet pressure ratings that are lower than their maximum inlet pressure ratings. A pressure relieving or pressure limiting device is needed if inlet pressure can exceed the maximum outlet pressure rating.

Refer to the Capacity Information section and the relief sizing coefficient in the specifications table to determine the required relief valve capacity.

The Type 67CFR regulator has a low capacity internal relief valve for minor seat leakage only. Other overpressure protection must be provided if the maximum

inlet pressure can exceed the maximum pressure rating of the downstream equipment or exceeds maximum outlet pressure rating of the Type 67CFR regulator.

Ordering Information

When ordering, complete the Ordering Guide on page 8. Refer to the Specifications on page 2. Review the description to the right of each specification and the information in each referenced table or figure. Specify your choice whenever a selection is offered.

Bulletin 71.1:67CF

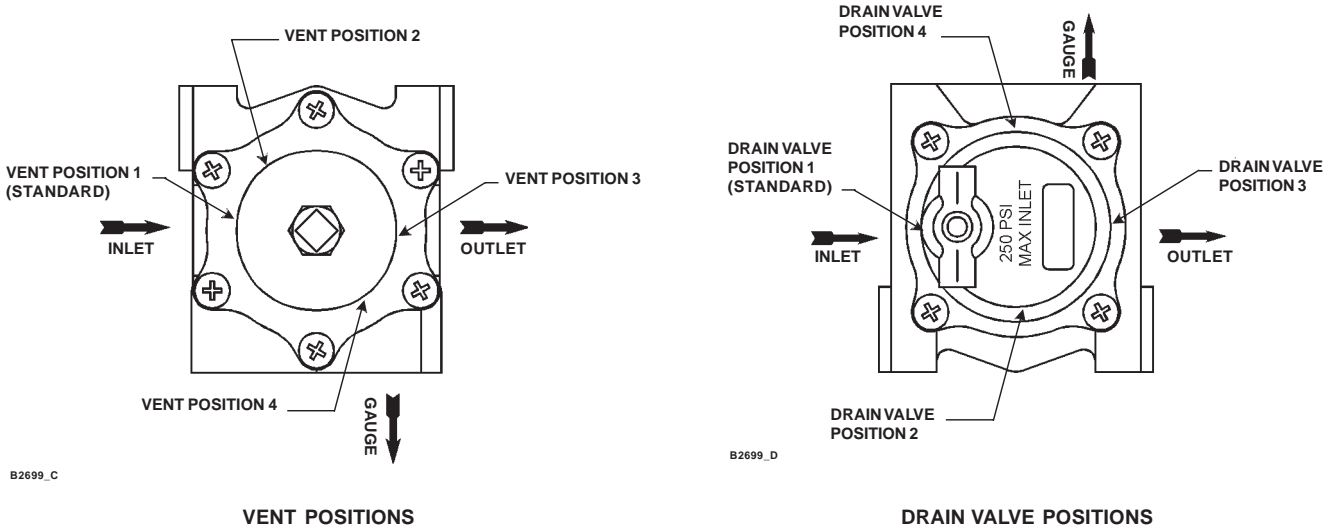
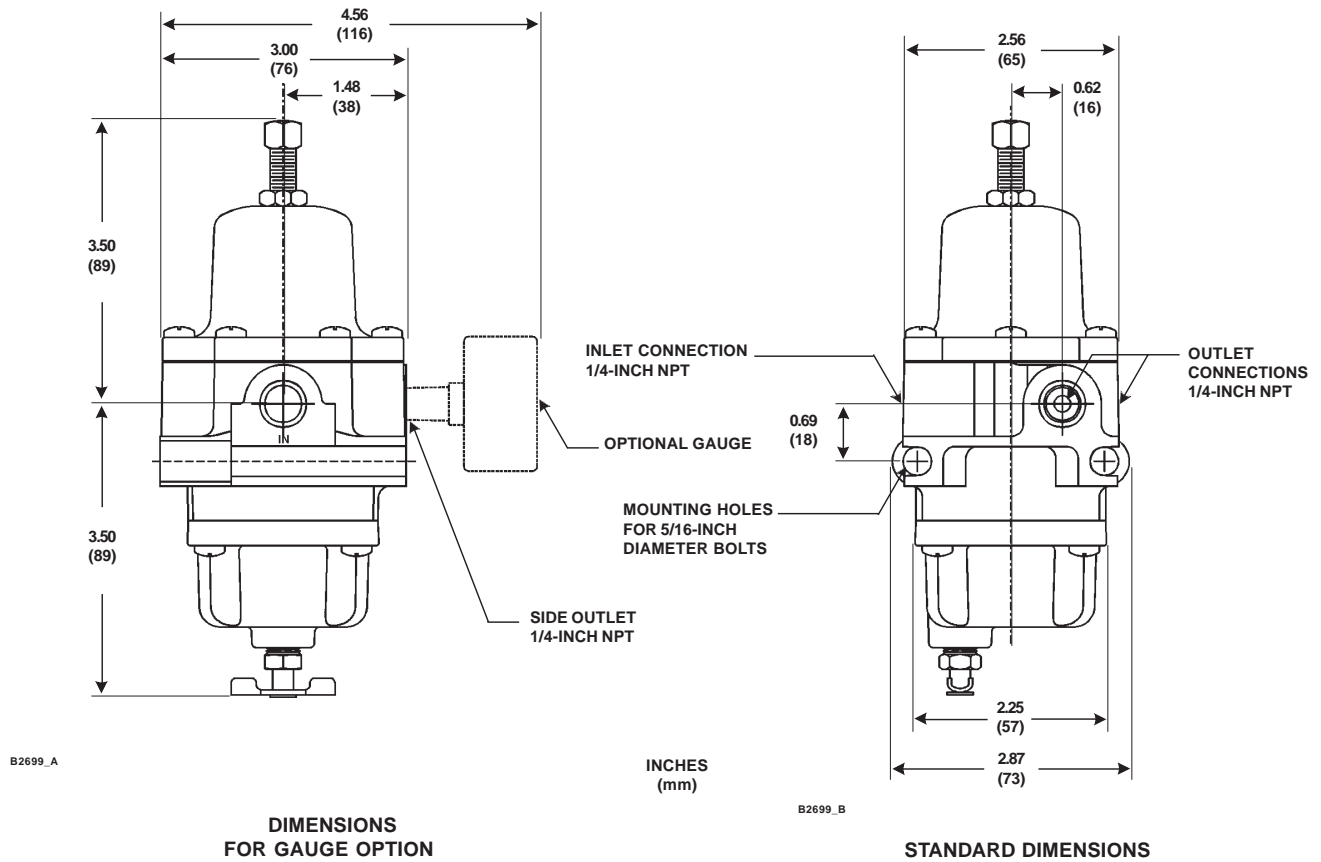

Figure 4. Dimensions

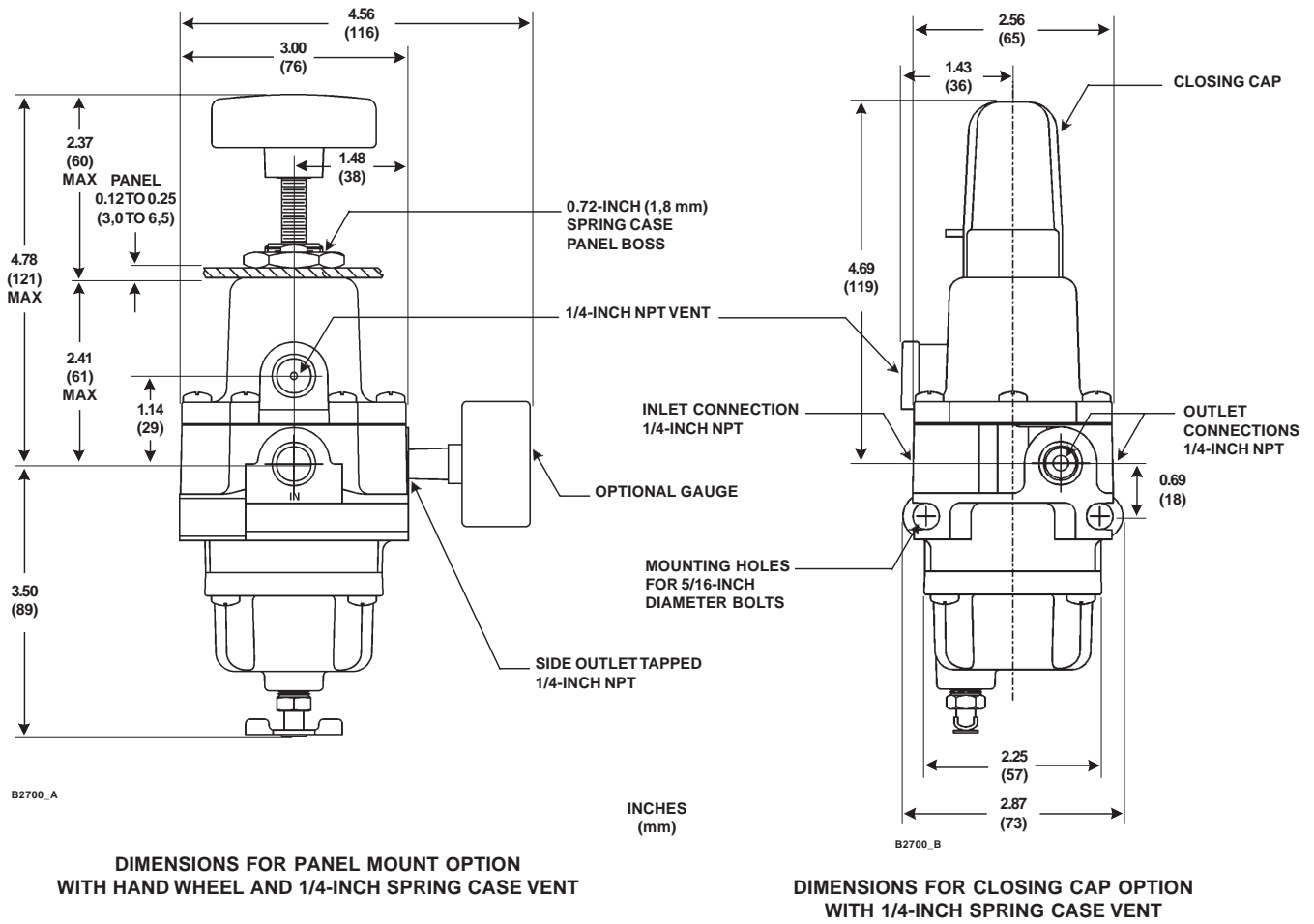

Figure 4. Dimensions (continued)

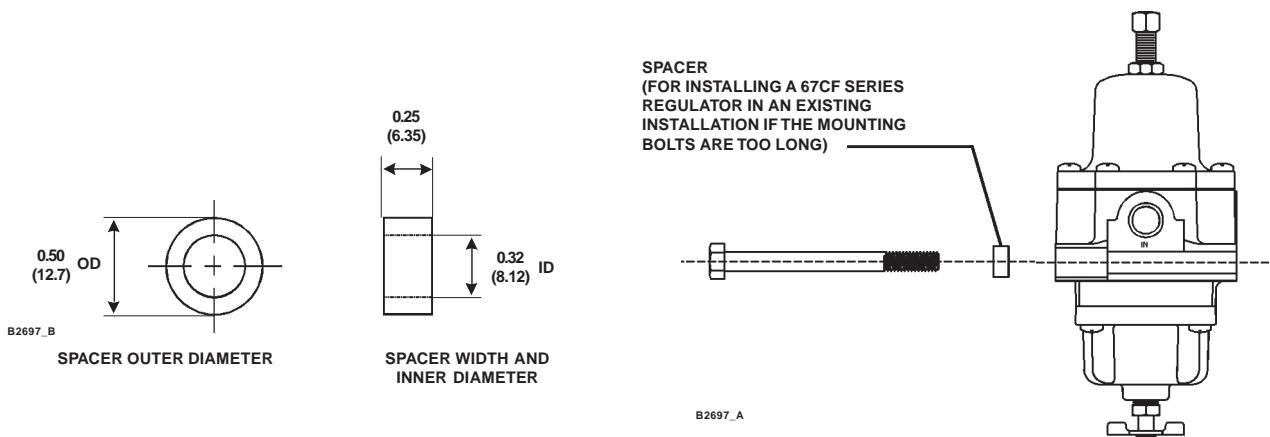

Figure 5. Spacer Dimensions and Installation Schematic

Bulletin 71.1:67CF

Ordering Guide

Type (Select One)

- Type 67CF (without internal relief)***
- Type 67CFR (with internal relief)***

Quantity (Specify)

Spring Case Style (Select One)

- Standard with drilled hole vent***
- Handwheel adjusting screw***
- Panel mount (includes 1/4-inch spring case vent, handwheel adjusting screw, and mounting nut)***
- Closing cap and 1/4-inch NPT spring case vent***

Outlet Pressure Range (Select One)

- 0 to 20 psig (0 to 1,4 bar) (not available for NACE)***
- 0 to 35 psig (0 to 2,4 bar)***
- 0 to 60 psig (0 to 4,1 bar)***
- 0 to 125 psig (0 to 8,6 bar)***

Diaphragm, O-Rings, and Valve Plug (Select One)

- Nitrile (NBR) (standard)***
- Fluoroelastomer (FKM)**
- Silicone (VMQ) diaphragm, O-rings, and nitrile valve plug*

Filter Material (Select One)

- Cellulose (40 microns) (standard)***
- Glass (10 microns)***
- Stainless steel (40 microns)***

Drain Valve (Select One)

- Brass (standard)***
- Aluminum***
- Stainless steel***

Drain Valve Location (Select One)

- Position 1 - Aligned with inlet (standard)***
- Position 2
- Position 3
- Position 4

Spring Case Vent Location (Select One)

- Position 1 - Aligned with inlet (standard)***
- Position 2
- Position 3
- Position 4

Second Outlet (Select One)

- Open (standard)***
- Plugged with pipe plug***
- Tire Valve***
- Pressure Gauge (see below)

Triple Scale Pressure Gauge (Optional)

Brass Gauge

- 0 to 30 psig/0 to 0.2 MPa/0 to 2 bar***
- 0 to 60 psig/0 to 0.4 MPa/0 to 4 bar***
- 0 to 160 psig/0 to 1.1 MPa/0 to 11 bar***

Stainless Steel Gauge

- 0 to 30 psig/0 to 0.2 MPa/0 to 2 bar***
- 0 to 60 psig/0 to 0.4 MPa/0 to 4 bar***
- 0 to 160 psig/0 to 1.1 MPa/0 to 11 bar***

NACE (MR0175) Construction (Optional)

- Yes**

Ammonia Service Construction (Optional)

- Yes**

Replacement Parts Kit (Optional)

- Yes, send one replacement parts kit to match this order.

Fisher Regulators Quick Order Guide	
***	Standard - Readily Available for Shipment
**	Non-Standard - Allow Additional Time for Shipment
*	Special Order, Constructed from Non-Stocked Parts. Consult Your Fisher Sales Representative for Availability.
Availability of the product being ordered is determined by the component with the longest shipping time for the requested construction.	

Specification Worksheet

Application (Please designate units):

Specific Use _____

Line Size _____

Gas Type and Specific Gravity _____

Gas Temperature _____

Does the Application Require Overpressure Protection?

No Yes, if so, which is preferred:

Relief Valve Monitor Regulator Shutoff Device

Is overpressure protection equipment selection assistance desired? _____

Pressure (Please designate units):

Maximum Inlet Pressure (P_{1max}) _____

Minimum Inlet Pressure (P_{1min}) _____

Downstream Pressure Setting(s) (P_2) _____

Maximum Flow (Q_{max}) _____

Performance Required:

Accuracy Requirements? _____

Need for Extremely Fast Response? _____

Other Requirements: _____

Fisher, Fisher-Rosemount, and Managing The Process Better are marks owned by Fisher Controls International, Inc. or Fisher-Rosemount Systems, Inc. All other marks are the property of their respective owners.

©Fisher Controls International, Inc., 1999; All Rights Reserved

The contents of this publication are presented for informational purposes only, and while every effort has been made to ensure their accuracy, they are not to be construed as warranties or guarantees, express or implied, regarding the products or services described herein or their use or applicability. We reserve the right to modify or improve the designs or specifications of such products at any time without notice.

For information, contact Fisher Controls:

Marshalltown, Iowa 50158 USA
 28320 Gallardon, France
 Sao Paulo 05424 Brazil
 Singapore 128461



FISHER-ROSEMOUNT™ Managing The Process Better™

